

## User Manual



# Hydrocar

The clean energy education kit

Made in China

[www.horizonfuelcell.com](http://www.horizonfuelcell.com)

Powered by  
**Horizon**



Model No.: FCJJ-20

### Warning

To avoid the risk of property damage, serious injury or death:

This kit should only be used by persons 12 years old and up, and only under the supervision of adults who have familiarized themselves with the safety measures described in the kit. Keep small children and animals away, as it contains small parts that could be swallowed. The fuel cell generates gases that are very easily ignited. Read the instructions before use and have them ready for reference.

# User Manual

## Table of Contents:

1. About the Hydrocar	p1
2. General safety instructions	p6
3. List of components	p7
4. Assembly of the car kit	p8
5. Electrolysis: create Hydrogen from water	p11
6. Hydrogen Fuel Cell Car operation	p16
7. Advice for optimal operation	p17
8. Troubleshooting	p19

## I. About the Hydrocar

The **Hydrocar** is a futuristic educational kit that contains one of the most exciting and advanced technologies of the 21st century. This kit operates on 100% clean fuel produced by a reversible fuel cell that converts water to hydrogen using energy captured from the sun. To help improve the quality of our environment, reduce the impact of soaring energy costs, and decrease our dependence on imported oil, the time is right to start introducing the world to the benefits of hydrogen fuel cell technologies.

Around the world, scientists and researchers are looking to find new ways to meet our growing energy needs without further damaging our environment or endangering our planet. One alternative is hydrogen, which can be created using clean, renewable sources such as wind and solar power. Using a device called an electrolyzer, water can be used to form hydrogen. Fuel cells can then convert hydrogen to electrical energy to power anything from vehicles and homes to electronic devices.

This **Hydrocar** kit is conveniently designed to bring the latest research out of the laboratories and into your hands - so that you too can join the global scientific community in bringing the world into the Hydrogen Age.

### a. Why Hydrogen?

Our civilization consumes carbon-based fossil fuels 100,000 times faster than they are being made available, raising many questions about global supplies and whether they are able to meet the world's fast-growing global energy demand. With geopolitical uncertainties in oil producing countries and insufficient oil refining capacity, our global economy is already under significant pressure. Oil is critical to the well-being of entire nations, therefore new technologies that can reduce the dependence on imported oil are becoming strategic. National security concerns are now encouraging scientists from all over the world to develop new energy technology solutions such as hydrogen fuel cells.

An even greater issue has to do with the consumption of oil itself. Fossil fuels contain carbon, and burning gasoline in our vehicles creates toxic air pollution in our cities and contributes to massive amounts of carbon dioxide being released into our atmosphere. Carbon dioxide accumulation is the cause of greenhouse effects and global warming. For more than 100 years, humans have burned tremendous amounts of carbon-based fuels, causing our atmosphere to heat up. Global warming can now be witnessed by increasingly violent storms, desertification, shrinking mountain glaciers, melting polar ice caps, changing ocean currents and rising sea water levels. We are just starting to notice the effects.

Our society needs a new and renewable fuel and hydrogen is the best solution for the long term.

Indeed, hydrogen is the most abundant element in our universe and carries the most energy per unit of weight. This carbon-free fuel can be produced either by using traditional or renewable power sources such as solar or wind power. Once captured, hydrogen can be converted back to usable energy in numerous applications, including vehicles. This means our every day fuel can be produced locally, and in unlimited quantities. When it is consumed in the fuel cell, the result is electricity and water. This water can then be used to produce hydrogen and oxygen, making the cycle continuous and natural, with no toxic emissions. There are many challenges to making this a reality, but it's only a matter of time... ..and human ingenuity!



Around the world, several "Hydrogen Highway" projects are being developed and over 200 hydrogen refueling stations have already been built to service the first fuel cell vehicles.

## b. What is a fuel cell and how does it work?

A fuel cell is a device that can convert hydrogen to usable electric power. The fuel cell is an assembly of advanced material layers where hydrogen and oxygen react with each other to generate electricity and water, without any combustion.

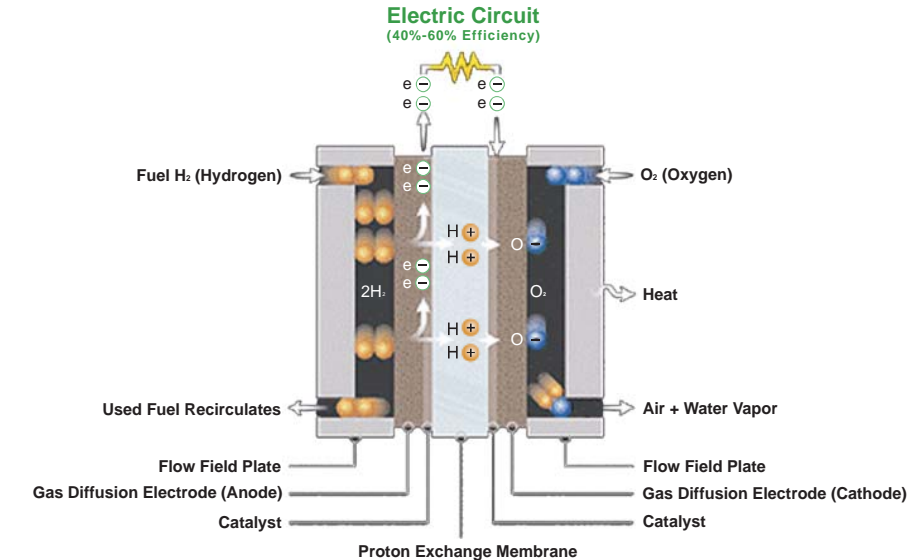

Serious interest in fuel cells did not begin until the 1960's, when they were used as power for mans first missions to the moon. Although fuel cells still provide electricity and water for today's space missions, this unique technology is now aimed at promoting a global transition to renewable energy sources. Fuel cell cars that use hydrogen as fuel are called "zero emission vehicles." If fuel cell cars were to use hydrogen produced by renewable sources of energy such as solar or wind power, our fuel supply would be unlimited - and consumption of hydrogen through fuel cells would not create any waste nor air pollution.

The **Hydrocar** uses a reversible Proton Exchange Membrane (PEM) fuel cell (see section 3, List of components - part C). It generates electrical energy by consuming hydrogen located in the on-board hydrogen storage cylinder (see section 3, List of parts and components, part G) which reacts with oxygen, which is also created and stored on-board the car.

The **Hydrocar** will independently find its way past any obstacles in its path. You will see it run and reverse until it can find a forward direction clear of barriers. When the car runs on its own hydrogen, two bright blue LED lights will start to flash from the top of the car's motor.

Now build your own hydrogen car to learn about this revolutionary energy technology!

## 2. General safety Instructions

**To avoid the risk of property damage, serious injury or death:**

1. Read carefully and fully understand the instructions before starting assembly of this kit.
2. This kit is intended only for use by persons 12 years old and up, and only under the supervision of adults who have read and understood the instructions in this user manual.
3. When assembling this kit, tools may be used. Extra care should be taken to avoid personal injury.
4. Some parts are small and fragile; please be careful when handling and connecting parts to avoid breakage. Handle all parts and components with care.
5. Do not attempt to use any part, item, or component provided in this kit for any other purpose than what is instructed in this manual. Do not attempt to disassemble any part, item or component in this kit.
6. Turn off the battery pack when not in use. When the battery pack is turned on, do not allow the metal leads to touch. Remove the batteries after use, and during storage.
7. Empty all water, hydrogen and oxygen from each component after use.
8. Clean your hands after working with the kit.

### 3. List of Components

- A. Syringe
- B. Short rubber tubes (see Chapter 4, Step 1)
- C. Reversible Fuel Cell
- D. Solar panel
- E. Kit chassis with motor and LED lights
- F. Battery pack
- G. Inner cylinders
- H. Outer cylinders
- I. Long rubber tubes (see Chapter 4, Step 1)

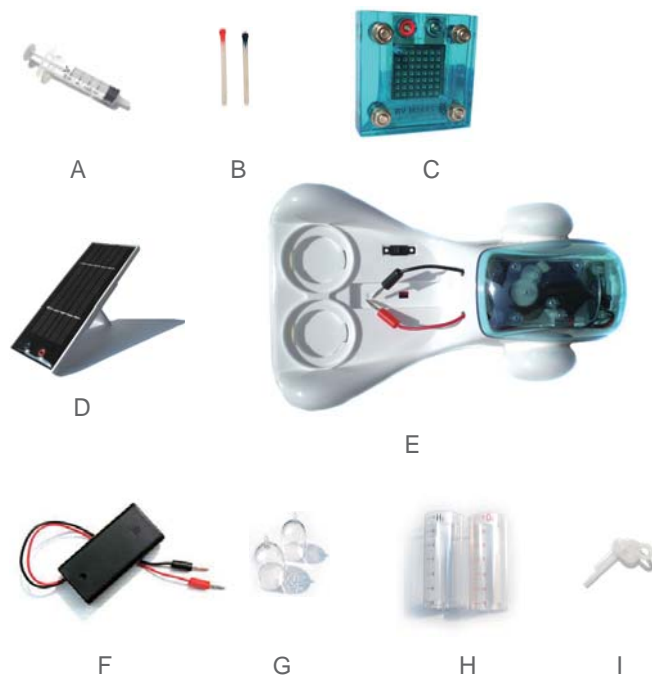

You will also need the following 3 items (not included in this kit):

- 2 AA batteries (alkaline batteries highly recommended)
- Scissors
- 100 ml of distilled water\*

\* Distilled water is highly recommended for optimal use.

### 4. Assembly of the kit

**Step 1:** Use the scissors (not included in this kit) to cut out two lengths of 4 cm (1.5 inches) of rubber tubing from the long rubber tube provided in the kit. Place the red pin into one of the 4 cm (1.5 inches) rubber tubes, and the black pin into the other 4 cm (1.5 inches) rubber tube. These short rubber tubes become part (B) of the kit. Cut the remaining long rubber tube into two equal pieces. These two longer pieces will be used to form part (I) of the kit.

**Step 2:** Attach the short rubber tube (B) with the black pin to the top nozzle on the hydrogen side of the fuel cell (marked H<sub>2</sub>). Attach the other short rubber tube (B) with the red pin to the top nozzle on the oxygen side of the fuel cell (marked O<sub>2</sub>).

**Step 3:** Insert the fuel cell (C) with the attached short rubber tubes (B) into the rectangular slot on the chassis (E).

**Step 4:** Insert the hydrogen and oxygen outer storage cylinders (H) into the round slots located on the chassis (E). Fill the cylinders with distilled water up to the 20 mark on each of the outer storage cylinders (H).

Insert the inner cylinders (G) into the outer cylinders (H) so that the inner cylinders (G) are filled with water. There are two notches at the bottom of each of the inner cylinders (G). These openings allow for gas to escape the inner cylinders (G) into the outer cylinders (H) to limit the amount of gas stored. Make sure these openings are not blocked by the raised plastic frame holding the inner cylinders (G). Push on the top of the inner cylinders (G) to be sure they fit firmly onto the plastic rim located at the bottom of the outer storage cylinders (H).

**Step 5:** Attach the long tubes (I) to the top of the inner cylinders (G). Attach the long tube coming from the hydrogen storage cylinder to the lower nozzle of the hydrogen side of the fuel cell. Attach the long tube coming from the oxygen storage cylinder to the lower nozzle of the oxygen side of the fuel cell.



**Step 6:** Good ion conductivity is critical to the performance of the fuel cell. In order to ensure good conductivity, the fuel cell's membrane needs to be properly humidified.

In order to hydrate the fuel cell, complete the following points:

Use the syringe (A) to suck distilled water (purchased separately) into the syringe. Once the syringe is filled with distilled water, place the syringe into the top nozzle on the oxygen side of the fuel cell (C) and proceed to push water into the oxygen side of the fuel cell (marked O<sub>2</sub>) until you see water passing through the chamber in front of the screen and out the lower nozzle. Leave the fuel cell for 5 to 10 minutes to fully hydrate.

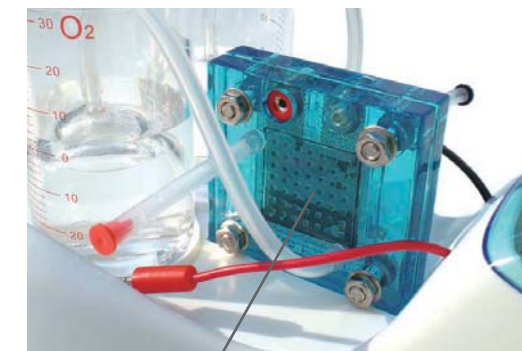

water

## 5. Electrolysis: create Hydrogen from water

Electrolysis is the process of converting electrical energy to chemical energy. When an electrical charge is applied to water, the charge breaks the chemical bond between hydrogen and oxygen and creates charged particles called ions. In this case, positively charged hydrogen ions and negatively charged ions are formed. An electrolyzer has 2 electrodes where the ions form. One electrode, called the anode, is positively charged, and attracts negatively charged ions. The other electrode is called the cathode and attracts the positively charged hydrogen ions.

Reversible fuel cells can be used to perform electrolysis. In a fuel cell, the electrolyte is part of the membrane assembly. When a current is applied to a fuel cell, it will electrolyze water producing hydrogen on the cathode side and oxygen on the anode side.

**Note:** Follow these next instructions only after you have completed all the steps in Chapter 4: "Assembly of the car kit". Make sure the fuel cell has been hydrated by injecting water using the syringe before proceeding to electrolysis.



**Warning:** Using non-distilled water damages the electrodes of the fuel cells. Fuel cells use nano-scale or carbon supported platinum as a catalyst, and these particles are very sensitive to impurities found in non-distilled water.

For the purposes of this hydrocar kit, high quality drinking water or tap water with low mineral content can also be used - however usability of the kit will inevitably be shortened.

The Fuel Cell must ONLY be hydrated through the O<sub>2</sub> side and NOT through the H<sub>2</sub> side, failure to do so will result in the blockage of hydrogen flow.

### a. Using Solar Panel for electrolysis

The Hydrocar kit can use a small solar photovoltaic cell for the electrolysis process as a way to capture renewable energy from the sun. Please follow the instructions below:

**Step 1:** Insert one end with the banana plug of the red cable into the red jack of the solar panel, the other end with the banana plug into the fuel cell.

**Step 2:** Insert one end with the banana plug of the black cable into the black jack of the solar panel, the other end with the banana plug into the fuel cell.

**Step 3:** Place the solar panel in direct sunlight. With strong, direct sunlight, you will see oxygen and hydrogen gases being produced in the inner gas cylinders. It will take approximately 5 - 10 minutes to fill up the inner hydrogen cylinder.



**Step 4:** The first time you operate electrolysis of water, it is possible that you will not arrive at the optimal result of hydrogen and oxygen production at a 2:1 ratio. To optimize the production of hydrogen, you will need to follow these points: Disconnect the solar panel from the fuel cell. Remove the red and black pins from the short tubes attached to the fuel cell to release hydrogen. After 2 seconds, quickly re-attach the pins to the short rubber tubes. You will need to complete this step to remove all inner gases from the fuel cell. Then repeat steps 1, 2 and 3.

**Step 5:** When you see the bubbles coming from the hydrogen cylinder and rising to the surface of the water, disconnect the solar panel from the fuel cell.

## b. Or using Battery Pack for electrolysis

**Step 1:** Make sure the battery pack (F) is switched to “off”. Insert 2 new AA batteries into the battery pack (F) provided in this kit. Do not use any other battery pack - this has been designed specifically for this reversible fuel cell.

**Step 2:** Be very careful to insert the red wire from the power jack into the red jack (oxygen side) of the fuel cell, and the black wire from the power jack into the black jack (hydrogen side) of the fuel cell. The fuel cell could be completely destroyed if the power supply is not connected properly.

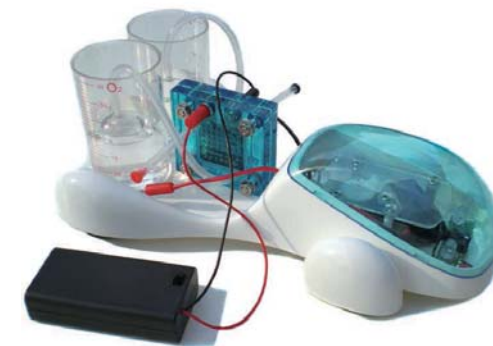

**Step 3:** Switch the battery pack to the “on” position to start electrolysis. You will know oxygen and hydrogen gases are being produced when water is displaced to the top of the water storage cylinders. You can also measure the gas produced by measuring what looks like empty space gradually increasing in the top of the inner cylinders (this takes approx 5 minutes). When the hydrogen inner cylinder is full of hydrogen gas, you will begin to see bubbles coming out of the inner cylinder into the outer cylinder. Electrolysis is completed when water in the inner cylinders is completely displaced at a 2:1 ratio (2 parts hydrogen, 1 part oxygen). The cylinder with more gas is the hydrogen cylinder.

**Step 4:** Switch the battery pack off. Follow the instructions in Part 5a, Step 4, in order to remove all inner gases from the fuel cell and optimize the production of hydrogen. Then repeat steps 2 and 3.

**Step 5:** When you see the bubbles coming from the hydrogen cylinder and rising to the surface of the water, switch off the battery pack and disconnect it from the fuel cell.

## 6. Hydrogen Fuel Cell Kit Operation

Once you have completed the assembly of the kit as described in “Chapter 4: Assembly of the kit”, and completed electrolysis as described in “Chapter 5: Electrolysis Operation”, you can run your fuel cell kit with hydrogen.

**Step 1:** Disconnect the solar panel from the fuel cell. If you used the battery pack, disconnect it from the fuel cell.

**Step 2:** Hold up the front of the kit so the motor does not touch the ground. Plug the red and black wires from the kit motor into the red and black jacks on the fuel cell. Place the kit on a smooth and flat surface and watch it go! The two blue LED lights on the front of the motor will also start to flash. The kit will independently find its way past any obstacles in its path, and you will see it turn and reverse until it can find a forward direction clear of barriers. The kit will continue to run on its own until all the hydrogen gas stored in the inner cylinder is consumed.



## 7. Advice for Optimal Operation

1. Make sure you use distilled water only. Any other water will contain substances and minerals that can contaminate and destroy the fuel cell. If you notice the fuel cell rusting – it means the appropriate water (distilled water) was not used for your experiments.
2. Only use the power pack provided and purchase 2 AA batteries, preferably alkaline batteries.
3. Make sure the fuel cell is well hydrated before any electrolysis operation by filling it with water using the syringe.
4. You will have maximum performance when the entire electrolysis process is repeated three to four times. This is due to the increased hydration of the PEM membrane in the fuel cell after repeated use. Optimal temperature: 20°C - 30°C. Make sure the reservoir is filled with distilled water to the zero mark on the outer cylinders before proceeding with electrolysis.
5. Ensure that the small outlets on the inner cylinders are not blocked by the plastic rim on the bottom of the outer cylinder. Hydrogen and oxygen are lighter than water so they flow to the top of the inner tube, displacing the water. If these small holes are blocked, too much pressure will build up inside the fuel cell and this will cause damage.
6. When you run the fuel cell multiple times, water in the upper part of the outer cylinder might not descend to the inner cylinder. This is because a vacuum has been created in the tubing. Disconnect the tubing from the upper nozzle of the fuel cell and the water will descend into the inner cylinder appropriately.

7. The fuel cell left in the open air is very sensitive to volatile organic compounds, which will affect the performance of the fuel cell. So when you are finished using the kit, it is highly recommended to place the fuel cell inside an air-sealed plastic bag, such as a ziploc bag. This will protect the fuel cell while you are not using your kit.
8. When using a solar panel, the current output of the solar panel should be no more than 0.7 A, and normal voltage no higher than 2V. A solar panel creating higher output and voltage may damage the fuel cell.
9. The fuel cell could be completely destroyed if the red wire of the battery pack is connected to the black jack of the fuel cell.
10. Make sure the fuel cell has been hydrated by injecting water using the syringe before proceeding to electrolysis. Leave the water inside the fuel cell for 5 to 10 minutes to fully hydrate the fuel cell.

## 8. Troubleshooting

1. **The water levels do not drop when the gas outlet tubes on both sides of the fuel cell are unplugged.**

Solution: Check whether the holes on the wall of the inner cylinder are blocked. If so, turn the inner cylinder until water enters the holes and fills up the inner cylinder.

2. **The electrolyzer does not produce hydrogen and/or oxygen.**

Solution: a. Check whether the wires are appropriately connected, and whether there are any loose connections. The fuel cell could be completely destroyed if the red wire of the battery pack is connected to the black jack of the fuel cell.

b. Check whether the switch of the battery pack is in the “on” position.

3. **The water electrolysis process slows down.**

Solution: a. Add water to the oxygen side of the fuel cell and wait for about 5 minutes.

b. Replace old AA batteries with new AA batteries inside the battery pack.

4. **The kit stops moving while there is still hydrogen left inside the tanks.**

Solution: a. Purge the gases and perform water electrolysis for 4-5 minutes. Unplug the hydrogen gas outlet tube and oxygen gas tubes to purge the gases. Perform water electrolysis again until the hydrogen tank is filled, and connect the motor to the fuel cell. If the problem persists, go to the next step.

b. Let the water electrolysis process last about 10 minutes to consume the residual water. To push water out of the fuel cell, purge the gases. Perform water electrolysis once more until the hydrogen tank is filled, then connect the motor to the fuel cell.

# welcome to the Hydrogen Age!

